



## Control approach 2

# Dust and fume from milling

# RB04

## Engineering control



This guidance sheet is for employers to help them comply with the requirements of the Control of Substances Hazardous to Health Regulations 2002 (COSHH) by controlling exposure to chemicals and protecting workers' health.

The sheet is part of HSE guidance *COSHH essentials: easy steps to control chemicals*. It describes the key points you need to follow to help reduce exposure to an adequate level. It is important to follow all the points, or use equally effective measures.

Rubber fume is given off in making natural or synthetic rubber when converting blended ingredients into finished parts or products.

Rubber fume can cause cancer.

Rubber process dust arises in rubber making where ingredients are handled, weighed, added to or mixed with uncured natural rubber or synthetic elastomers. Rubber process dust does not include dust from abrasion of cured rubber.

Rubber process dust can cause cancer.

For using other chemicals (eg when cleaning down, tackifying etc), refer to [www.coshh-essentials.org.uk](http://www.coshh-essentials.org.uk)

Control approach 2 (engineering control) is recommended to control rubber process dust and fume in milling.

For environmental advice see Further information on back page.

### Access

- ✓ Restrict access to those staff who need to be there.
- ✓ Display warning signs while cleaning.

### Design and equipment

- ✓ Keep dust exposures as low as possible. Enclose the mill as much as possible.
- ✓ If practical, fit strip curtains to keep dust and fume inside the enclosure.
- ✓ You need an air speed between 0.5 and 1 metres per second into the enclosure.
- ✓ Make sure a manometer or pressure gauge is fitted near the extraction point, to show that the extraction is working properly.
- ✓ Always confirm that the extraction is turned on and working at the start of work. Check the gauge.
- ✓ Also, extract fume given off from freshly milled rubber, eg on conveyors.
- ✓ Discharge cleaned, extracted air to a safe place outside the building, away from doors, windows and air inlets.
- ✓ Have a supply of clean air coming into the workroom to replace extracted air.
- ✓ You may need an alarm to warn of blockages.
- ✓ Consult a qualified ventilation engineer to design new control systems (see Control guidance sheet FD14).

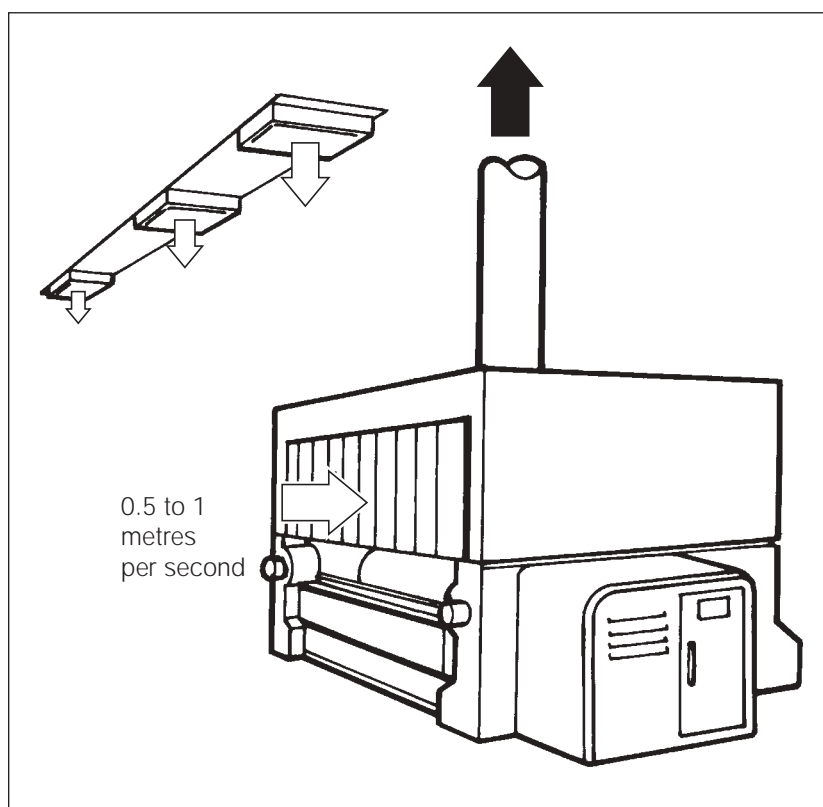

---

## Maintenance

- ✓ Follow instructions in maintenance manuals.
- ✓ Use a written system of work for maintenance and define the PPE necessary.
- ✓ Keep equipment in effective and efficient working order.
- ✓ Repair faulty extraction systems immediately. Meanwhile, wear respiratory protective equipment (RPE).

## Examination and testing

- ✓ Look daily for signs of damage to the mill, ducting and air filter. Repair damage immediately.
- ✓ At least once a week, check that the extraction system and gauge work properly.
- ✓ You need to know the manufacturer's performance specification to know if extraction is working properly.
- ✓ If this information isn't available, hire a competent ventilation engineer to determine its performance.
- ✓ The engineer's report must show the target air speeds.
- ✓ Keep this information in your testing logbook.
- ✓ Get a competent ventilation engineer to examine the system thoroughly and test its performance at least once every 14 months (see HSE publication HSG54).
- ✓ Keep records of all examinations and tests for at least five years.
- ✓ Review records to see if there are failure patterns that make planning maintenance easier.

## Cleaning and housekeeping

- ✓ Every day, clear up accumulations of dirt in areas where people work all the time.
- ✓ Deal with spills immediately. This needs coveralls, a respirator and single-use gloves.
- ✓ Clean general workrooms once a week to stop dust being stirred up and to reduce slips.
- ✓ Use a Type H vacuum cleaner fitted with a HEPA filter to clear up dust.
- ✗ Don't clean up with a brush or with compressed air.
- ✓ Use procedural controls, eg lock-off, before cleaning the mill.

## Personal protective equipment (PPE)

- ✓ Ask your safety-clothing supplier to help you get the right PPE.
  - ✓ Respiratory protective equipment (RPE) should not be needed if the extraction is designed correctly and working properly.
  - ✓ RPE is needed for maintenance and cleaning, and for clearing up spills.
  - ✓ Use a P3 standard of RPE (Assigned Protection Factor 20). Consult your supplier for advice.
  - ✓ Replace RPE filters as recommended by the supplier. Throw away disposable masks after one use.
  - ✓ Keep RPE clean and store it away from dust.
  - ✓ Protective gloves are needed. Use nitrile gloves.
  - ✓ Throw away single-use gloves every time you take them off.
  - ✓ Skin creams are important for skin protection and help in washing contamination from the skin. These are **not** 'barrier creams'. After work creams help to replace skin oils.
  - ✗ Never allow compressed air use for removing dust from clothing.
  - ✗ Workers must not take their coveralls home for washing. Use a contract laundry.
- 

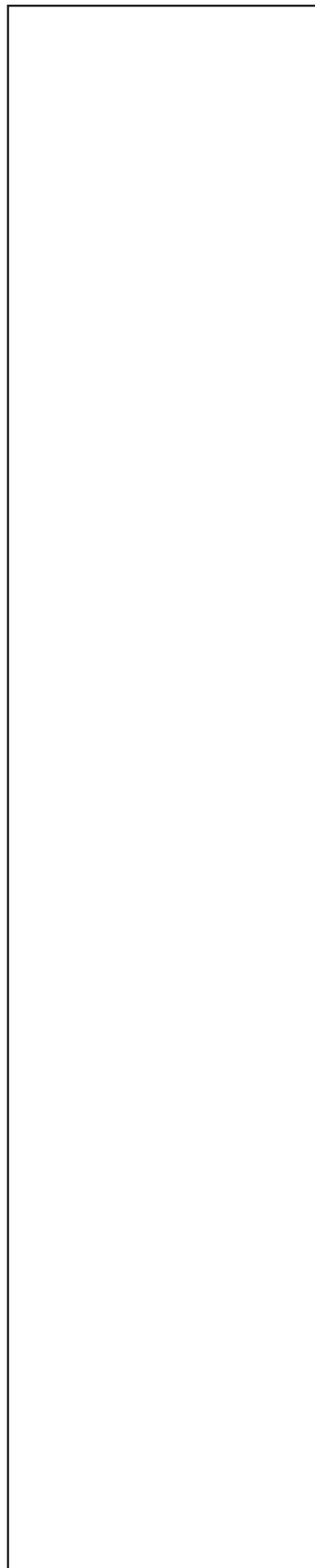

---

## Training

- ✓ Tell workers that rubber process dust and fume can cause cancer.
- ✓ Provide health and safety training. Include managers. Ask your trade association (eg BRMA or RMA) for advice on training providers.
- ✓ Ensure training includes how to keep exposures low; how to check that the extraction system is working; how to use and look after PPE and RPE; and what to do if something goes wrong.

## Supervision

- ✓ Check that the equipment is correctly locked-off for cleaning; PPE is being used properly; and the rules on personal hygiene are being followed.
- ✓ Ask your workers to check their skin for dryness or soreness every six months. If these effects appear, check the proper use of skin creams and PPE.

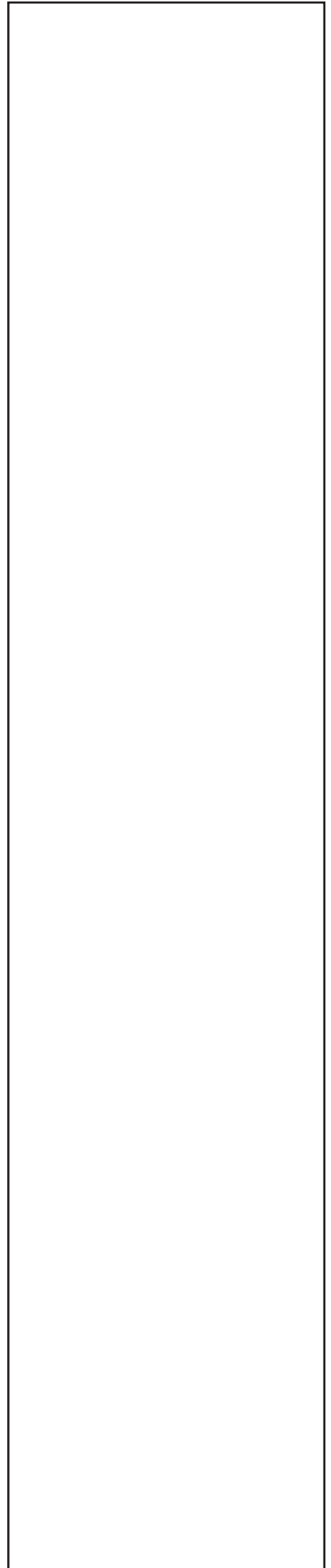

## Further information

- *A new practical guide to complying with COSHH in the rubber industry* Guidance HSE Books 1997 ISBN 0 7176 1372 0
- *Dust and fume control at rubber mixing and milling* Guidance HSE Books 1996 ISBN 0 7176 0992 8
- *Maintenance, examination and testing of local exhaust ventilation* HSG54 (Second edition) HSE Books 1998 ISBN 0 7176 1485 9
- *An introduction to local exhaust ventilation* HSG37 (Second edition) HSE Books 1993 ISBN 0 7176 1001 2
- *The selection, use and maintenance of respiratory protective equipment: A practical guide* HSG53 (Second edition) HSE Books 1998 ISBN 0 7176 1537 5
- *Safe to breathe: Dust and fume control in the rubber industry* Leaflet IACL95 HSE Books 1995 (single copy free or priced packs of 10 ISBN 0 7176 0979 0)
- *Controlling airborne contaminants in the workplace* Technical Guide TG7 British Occupational Hygiene Society 1987 ISBN 0 9059 2742 7
- See also Control guidance sheet 204 *Removing waste from a dust extraction unit*
- Health and safety consultants: the BOHS Faculty of Occupational Hygiene keeps lists of qualified hygienists who can help you. Contact BOHS on 0133 229 8087 or at [www.bohs.org/](http://www.bohs.org/)

Depending on the scale of work, releases into the atmosphere may be regulated within the pollution prevention and control (PPC) framework. You should consult your local authority or the Environment Agency. In Scotland, consult the Scottish Environment Protection Agency (SEPA). They will advise you if PPC legislation applies to your company, and about air cleaning and discharging emissions into the air. Otherwise, minimise emissions into the air.

## Employee checklist

- Always follow the standard operating procedures.
- Follow the method of work strictly. Is the equipment locked off before starting cleaning? Is someone posted outside?
- Is the extraction switched on and working properly?
- Check the gauge.
- Look for signs of leaks, wear and damage.
- If you find any problems, tell your supervisor. Don't just carry on working.
- Co-operate with lock-off procedures for mill cleaning.
- Use, maintain and store your PPE in accordance with instructions.
- Clear up spills immediately.
- Throw away single-use gloves every time you take them off.
- Wash your hands before and after eating, drinking, smoking and using the lavatory.
- Never use solvents to clean your skin.
- Use skin creams provided as instructed.



*COSHH essentials:  
easy steps to control chemicals*  
October 2003

Printed and published by  
the Health and Safety Executive